

Autodesk Simulation Tools and NAFEMS Benchmarks

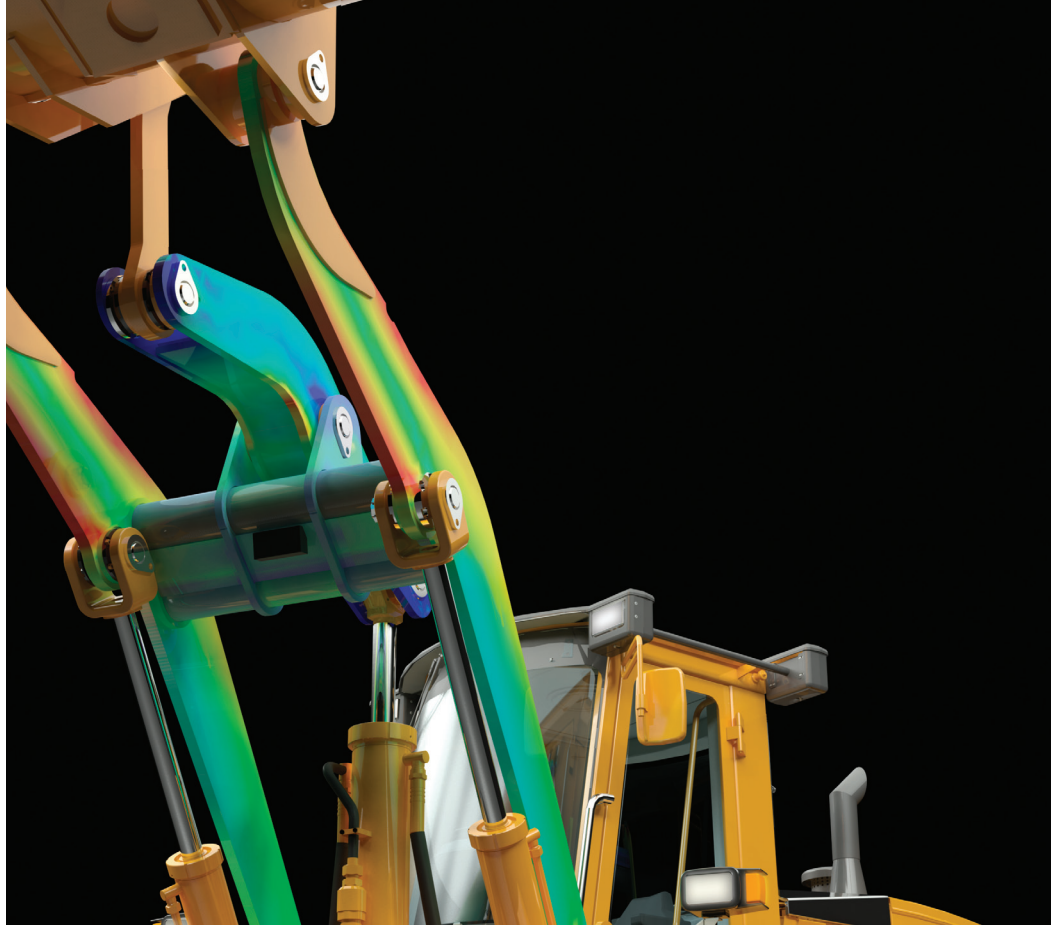

Introduction

This document contains 10 cases that compare results calculated in Autodesk® Inventor® 2011 Stress Analysis and Autodesk® Algor® Simulation 2011 against NAFEMS Benchmarks.

Each case contains several sections: case description, material data, dimensions, load value, mesh settings, results computed and corresponding references. Comparisons against stress, deformation and natural frequency are included in this document. All cases used the SI system of units.

All analyses are conducted with certain mesh settings. Better accuracy of results can be achieved with fine-tuning of settings, such as local mesh, convergence, and so on.

The summarized comparison shows the results calculated in Inventor 2011 Stress Analysis and Algor Simulation 2011 are close to NAFEMS Benchmarks.

Cases		Differences Compared to NAFEMS	
Case number	Case type	Inventor Stress Analysis 2011	Algor simulation 2011
1	Static Stress	2.13%	2.74%
2	Static Stress	0.25%	1.88%
3	Static Stress	1.43%	1.05%
4	Static Stress	0.76%	0.49%
5	Static Stress	0.00%	0.98%
6	Static Stress	0.25%	1.12%
7	Static Stress	3.25%	2.09%
8	Static Stress	2.04%	3.90%
9*	Natural frequency	0.04%	0.10%
10*	Natural frequency	3.83%	2.95%

* For natural frequency cases, only comparison results of first natural frequency are listed here.

Comparison of Autodesk Simulation tools to NAFEMS Benchmarks

1. Elliptic plate under tensile

Case description

An elliptic plate with thickness t is supported to a uniform outward pressure P on the outer elliptic cylindrical face, and unloaded at inner face. The plate is symmetric about YZ plane and ZX plane. Determine the tangential edge stress at corner point D on middle plane.

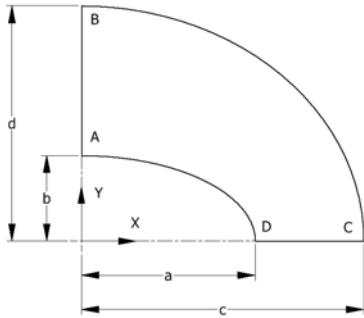

Material data

Steel	
Young's Modulus	2.1e+005 MPa
Poisson's Ratio	0.3
Mass Density	7.85e-006 kg/mm ³
Tensile Yield Strength	207.0 MPa

Dimensions

a = 2000 mm
 b = 1000 mm
 c = 3250 mm
 d = 2750 mm
 t = 100 mm

Load value

P = 10 MPa

Mesh Settings

	Element type	Mesh size
Inventor 2011	Tetrahedra	Default
Algor 2011	Bricks and Tetrahedra	Default

Results comparison

Tangential Stress(σ_{yy}) at point D		
Comparison results*	92.7 MPa	
Inventor 2011	Value	90.73 MPa
	Percentage Difference	2.13%
Algor 2011	Value	90.16 MPa
	Percentage Difference	2.74%

* Reference: NAFEMS Benchmark Test LE1

Results display in Inventor 2011

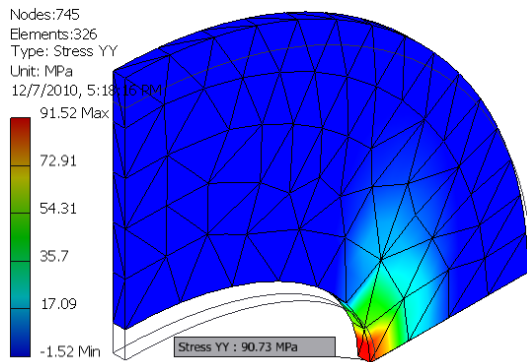

Results display in Algor 2011

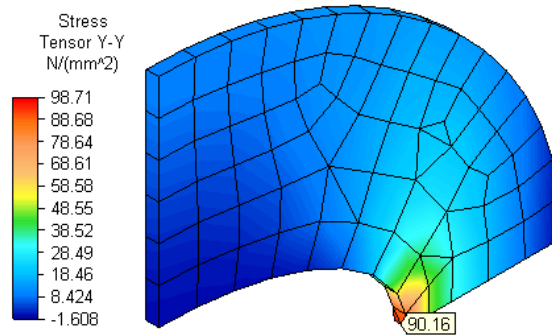

Comparison of Autodesk Simulation tools to NAFEMS Benchmarks

2. Cylindrical shell patch under moment

Case description

A cylindrical shell patch with thickness t is subjected to a uniform normal moment M on one side, including edge CD. The shell is fully constrained on the other side, including edge AB, and symmetrical about two ends. Determine the tangential stress at point E on outer surface of shell. Here the tangential direction at point E is along X axis by modeling.

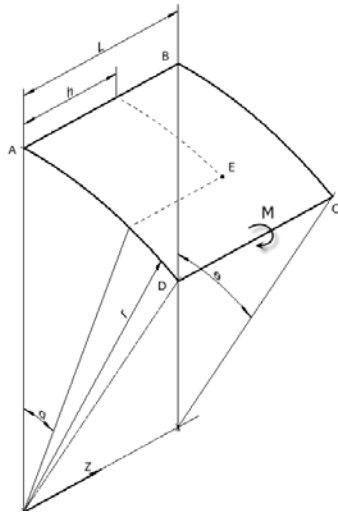

Material data

Steel	
Young's Modulus	2.1e+005 MPa
Poisson's Ratio	0.3
Mass Density	7.85e-006 kg/mm ³
Tensile Yield Strength	207.0 MPa

Dimensions

$L = 500$ mm
 $r = 1000$ mm
 $h = 300$ mm
 $\alpha = 20^\circ$
 $\theta = 30^\circ$
 $t = 10$ mm

Load value

$M = 5 \times 10^5$ N·mm

Mesh Settings

	Element type	Mesh size
Inventor 2011	Tetrahedra	Default
Algor 2011	Plate	Default

Results comparison

Tangential Stress at point E (stress σ_{xx})		
Comparison results*	60.0 MPa	
Inventor 2011	Value	59.85 MPa
	Percentage Difference	0.25%
Algor 2011	Value	58.87 MPa
	Percentage Difference	1.88 %

* Reference: NAFEMS Benchmark Test LE2

Results display in Inventor 2011

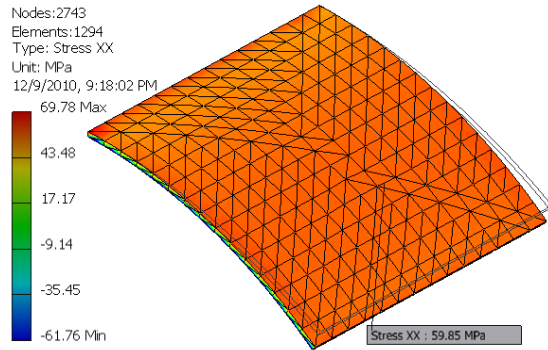

Results display in Algor 2011

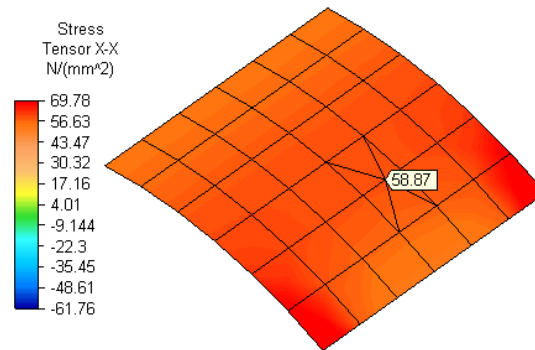

Comparison of Autodesk Simulation tools to NAFEMS Benchmarks

3. Cylindrical shell patch under pressure

Case description

A cylindrical shell patch with thickness t is subjected to a uniform outward pressure P_1 on top surface ABCD, and tangential outward pressure P_2 on the side including edge CD. The shell is fully constrained on the other side, including edge AB, and symmetrical about two ends. Determine the tangential stress at point E on outer surface of shell. Here the tangential direction at point E is along X axis by modeling.

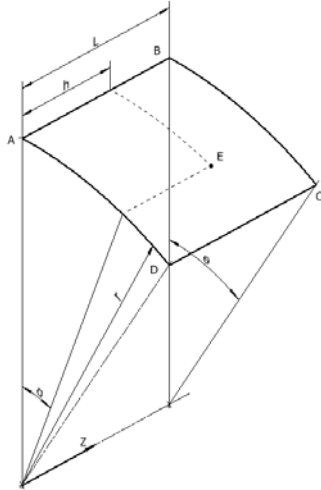

Material data

Steel	
Young's Modulus	2.1e+005 MPa
Poisson's Ratio	0.3
Mass Density	7.85e-006 kg/mm ³
Tensile Yield Strength	207.0 MPa

Dimensions

L = 500 mm
 r = 1000 mm
 h = 300 mm
 $\alpha = 20^\circ$
 $\theta = 30^\circ$
 t = 10 mm

Load value

$P_1 = 0.6$ MPa
 $P_2 = 60$ MPa

Mesh Settings

	Element type	Mesh size
Inventor 2011	All Tetrahedra	Default without curved mesh
Algor 2011	Plate	Default

Results comparison

Tangential Stress at point E (stress σ_{xx})		
Comparison results*	60.0 MPa	
Inventor 2011	Value	60.86 MPa
	Percentage Difference	1.43%
Algor 2011	Value	60.63 MPa
	Percentage Difference	1.05%

* Reference: NAFEMS Benchmark Test LE2

Results display in Inventor 2011

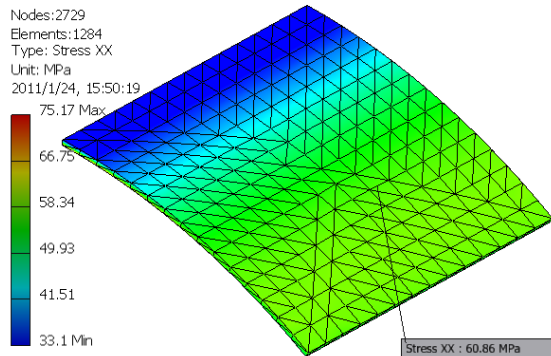

Results display in Algor 2011

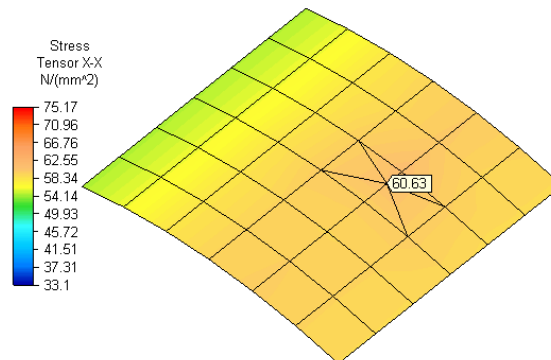

4. Hemisphere shell under concentrated loads

Case description

A hemisphere shell with thickness t is fixed at top point E and subjected to concentrated radial loads applied outwards at point A, and inwards at point C. Due to symmetry, one quarter of the hemisphere is modeled for analysis. Determine the X displacement at point A.

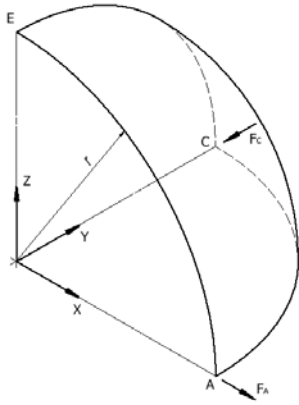

Material data

Steel	
Young's Modulus	68.25e+003 MPa
Poisson's Ratio	0.3
Mass Density	2.710E-006kg/mm ³

Dimensions

$r = 10000$ mm
 $t = 40$ mm

Load value

$F_A = 2000$ N
 $F_C = 2000$ N

Mesh Settings

	Element type	Mesh size
Inventor 2011	Tetrahedra	Default without curved mesh
Algor 2011	Plate	Default

Results comparison

X displacement at point A		
Comparison results*	185.0 mm	
Inventor 2011	Value	183.6 mm
	Percentage Difference	0.76%
Algor 2011	Value	184.1 mm
	Percentage Difference	0.49%

* Reference: NAFEMS Benchmark Test LE3

Results display in Inventor 2011

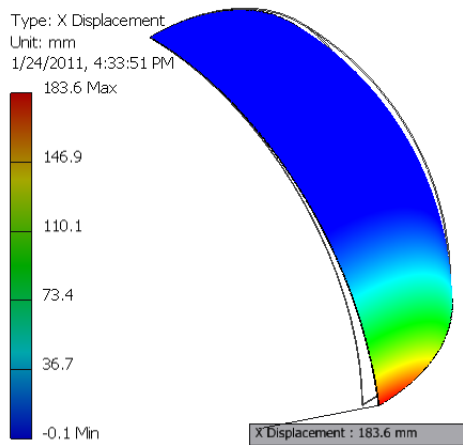

Results display in Algor 2011

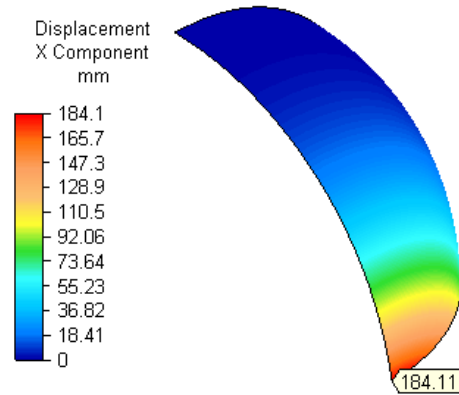

Comparison of Autodesk Simulation tools to NAFEMS Benchmarks

5. Z section beam under torsion

Case description

A cantilever Z section beam with thickness t is subjected to a $1.2E+006$ N-m torque on one end. Determine the axial stress of point A at middle surface.

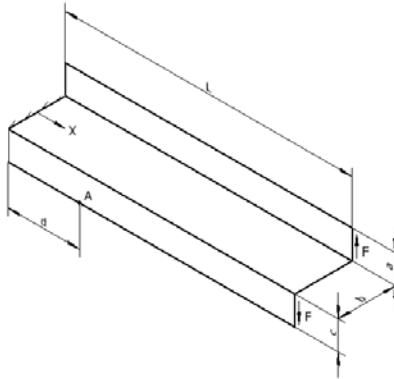

Material data

Steel	
Young's Modulus	2.1e+005 MPa
Poisson's Ratio	0.3
Mass Density	7.85e-006 kg/mm ³
Tensile Yield Strength	207.0 MPa

Dimensions

L = 10000 mm
 a = 1000 mm
 b = 2000 mm
 c = 1000 mm
 d = 2500 mm
 t = 100 mm

Load value

F = 600000 N

Mesh Settings

	Element type	Mesh size
Inventor 2011	Tetrahedra	0.05
Algor 2011	All Tetrahedra with Middleside nodes	Default

Results comparison

Axial stress(σ_{xx}) at point A on mid-surface		
Comparison results*	108 MPa	
Inventor 2011	Value	108.0 MPa
	Percentage Difference	0.00%
Algor 2011	Value	106.94 MPa
	Percentage Difference	0.98%

* Reference: NAFEMS Benchmark Test LE5

Results display in Inventor 2011

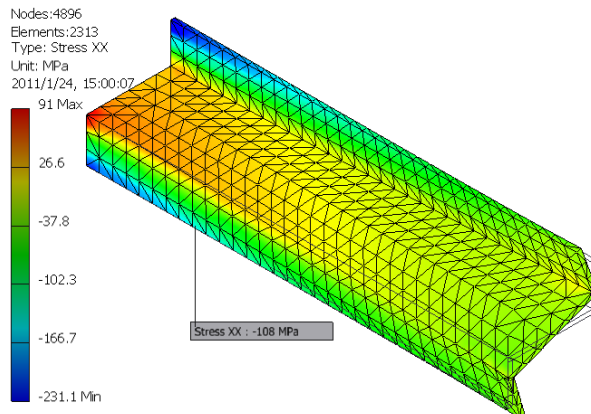

Results display in Algor 2011

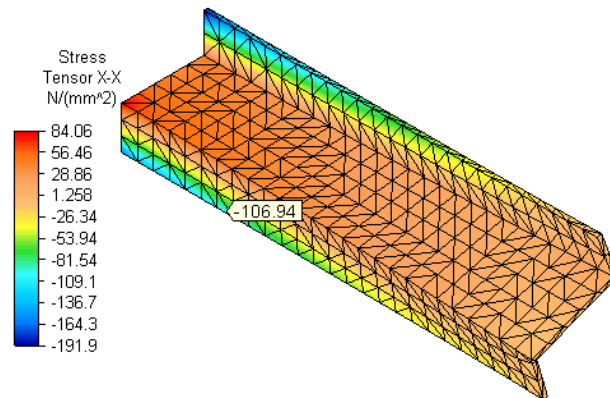

Comparison of Autodesk Simulation tools to NAFEMS Benchmarks

6. Skew plate under normal pressure

Case description

A rhombic skew plate with thickness t and length L is subjected to a normal pressure P on top face. The plate is simply supported on four side faces. Determine the maximum principle stress at plate center point E on bottom surface.

Material data

Steel	
Young's Modulus	2.1e+005 MPa
Poisson's Ratio	0.3
Mass Density	7.85e-006 kg/mm ³
Tensile Yield Strength	207.0 MPa

Dimensions

$L = 1000$ mm
 $t = 10$ mm

Load value

$P = 0.0007$ MPa

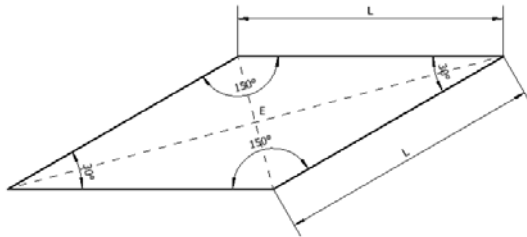

Mesh Settings

	Element type	Mesh size
Inventor 2011	All Tetrahedra	0.03
Algor 2011	All Tetrahedra with midside nodes	30%

Results comparison

Maximum principle stress at point E		
Comparison results*	0.802 MPa	
Inventor 2011	Value	0.804 MPa
	Percentage Difference	0.25%
Algor 2011	Value	0.811 MPa
	Percentage Difference	1.12%

* Reference: NAFEMS Benchmark Test LE6

Results display in Inventor 2011

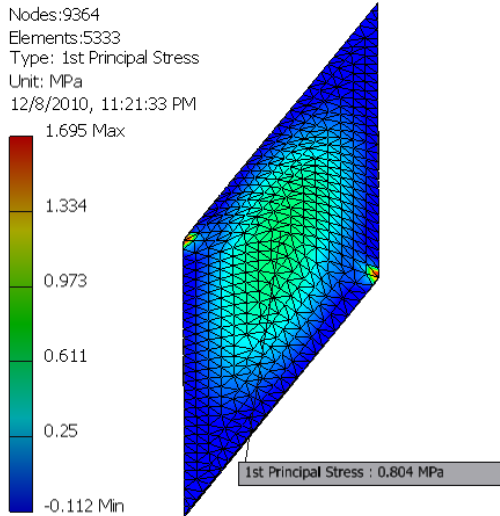

Results display in Algor 2011

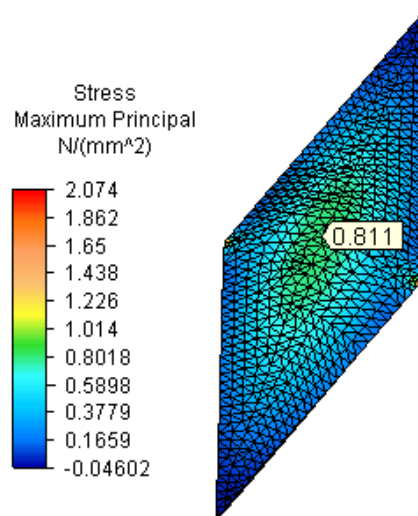

Comparison of Autodesk Simulation tools to NAFEMS Benchmarks

7. Axisymmetric cylinder/sphere shell under pressure

Case description

An axisymmetric shell composed of cylinder and hemisphere with thickness t is subjected to an inner pressure valued P . The shell is symmetric about bottom surface. Determine the axial stress at point D on outer surface.

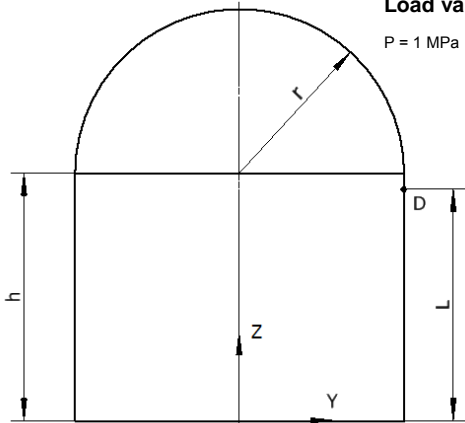

Material data

Steel	
Young's Modulus	2.1e+005 MPa
Poisson's Ratio	0.3
Mass Density	7.85e-006 kg/mm ³
Tensile Yield Strength	207.0 MPa

Dimensions

h = 1500 mm
r = 1000 mm
L = 1403.4 mm
t = 25 mm

Load value

P = 1 MPa

Mesh Settings

	Element type	Mesh size
Inventor 2011	All Tetrahedra	Default
Algor 2011	2D Axisymmetry	10 mm

Results comparison

Axial stress (σ_{zz}) at point D on outer surface		
Comparison results*	25.86 MPa	
Inventor 2011	Value	25.02 MPa
	Percentage Difference	3.25%
Algor 2011	Value	25.32 MPa
	Percentage Difference	2.09%

* Reference: NAFEMS Benchmark Test LE7

Results display in Inventor 2011

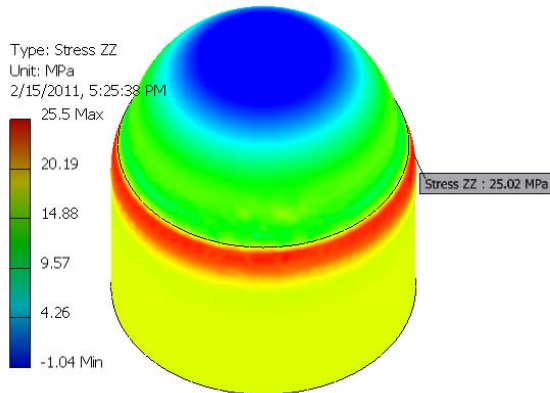

Results display in Algor 2011

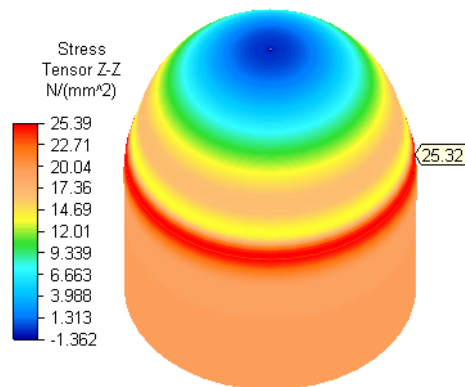

8. Thick elliptic plate under normal pressure

Case description

A thick elliptic plate with thickness t is subjected to a normal pressure P on its top surface. Face $CC'D'D$, $ABB'A'$ and middle surface have no Y , X and Z direction displacement, and X and Y displacement of face $BCC'B'$ are fixed. Determine the direct stress along Y direction at point D .

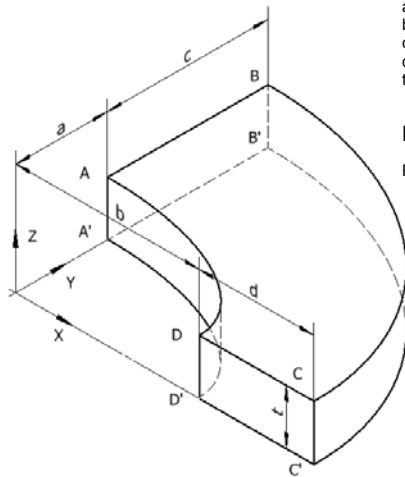

Material data

Steel	
Young's Modulus	2.1e+005 MPa
Poisson's Ratio	0.3
Mass Density	7.85e-006 kg/mm ³
Tensile Yield Strength	207.0 MPa

Dimensions

a = 1000 mm
 b = 2000 mm
 c = 1750 mm
 d = 1250 mm
 t = 600 mm

Load value

P = 1 MPa

Mesh Settings

	Element type	Mesh size
Inventor 2011	All Tetrahedra	Default
Algor 2011	Bricks and tetrahedra	Default

Results comparison

Axial stress(σ_{yy}) at point D		
Comparison results*	5.38 MPa	
Inventor 2011	Value	5.27 MPa
	Percentage Difference	2.04%
Algor 2011	Value	5.59 MPa
	Percentage Difference	3.90%

* Reference: NAFEMS Benchmark Test LE10

Results display in Inventor 2011

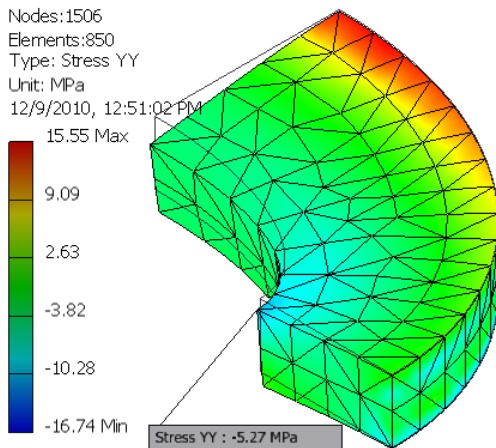

Results display in Algor 2011

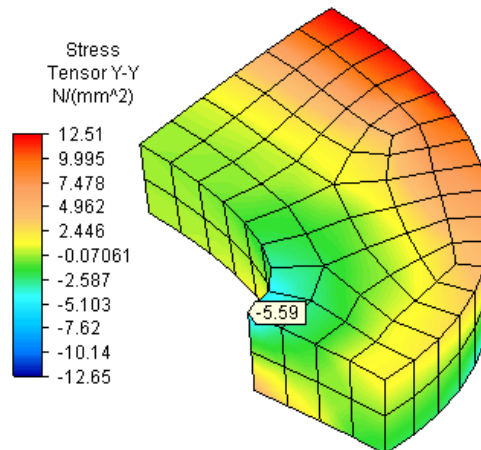

Comparison of Autodesk Simulation tools to NAFEMS Benchmarks

9. In-plane vibration of a pin-ended double cross

Case description

A part of double cross with square section of side w is pinned at 8 ends, and is constrained to vibrate in plane. Determine the first 16 natural frequencies of this model.

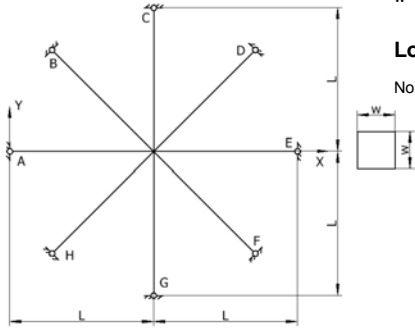

Material data

Steel	
Young's Modulus	2.0e+005 MPa
Poisson's Ratio	0.3
Mass Density	8e-006 kg/mm ³

Dimensions

L = 5000 mm
w = 125 mm

Load value

None

Mesh Settings

	Element type	Mesh size
Inventor 2011	All Tetrahedra	0.01
Algor 2011	Beam	5 segments on each branch

Results Comparison

First 16 natural frequencies		F1	F2	F3	F4	F5	F6	F7	F8
Comparison results*		11.336 HZ	17.709 HZ	17.709 HZ	17.709 HZ	17.709 HZ	17.709 HZ	17.709 HZ	17.709 HZ
Inventor 2011	Value	11.34 HZ	18.55 HZ	18.57 HZ	18.57 HZ	18.57 HZ	18.58 HZ	18.58 HZ	18.60 HZ
	Percentage Difference	0.04%	4.75%	4.86%	4.86%	4.86%	4.92%	4.92%	5.03%
Algor 2011	Value	11.325 HZ	17.631 HZ	17.631 HZ	17.659 HZ	17.659 HZ	17.659 HZ	17.659 HZ	17.659 HZ
	Percentage Difference	0.10%	0.44%	0.44%	0.28%	0.28%	0.28%	0.28%	0.28%
First 16 natural frequencies		F9	F10	F11	F12	F13	F14	F15	F16
Comparison results*		45.345 HZ	57.390 HZ	57.390 HZ	57.390 HZ	57.390 HZ	57.390 HZ	57.390 HZ	57.390 HZ
Inventor 2011	Value	45.22 HZ	59.72 HZ	59.83 HZ	59.87 HZ	59.87 HZ	59.90 HZ	59.94 HZ	59.95 HZ
	Percentage Difference	0.28%	4.06%	4.25%	4.32%	4.32%	4.37%	4.44%	4.46%
Algor 2011	Value	44.882 HZ	55.772 HZ	55.772 HZ	56.052 HZ	56.052 HZ	56.052 HZ	56.052 HZ	56.052 HZ
	Percentage Difference	1.02%	2.82%	2.82%	2.33%	2.33%	2.33%	2.33%	2.33%

* Reference: NAFEMS Benchmark Test FV2

Comparison of Autodesk Simulation tools to NAFEMS Benchmarks

Results display in Inventor 2011

1st mode shape

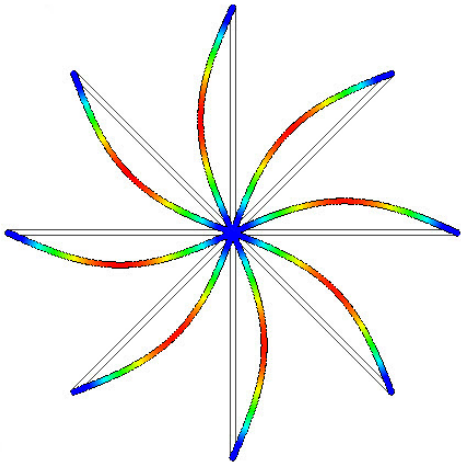

9th mode shape

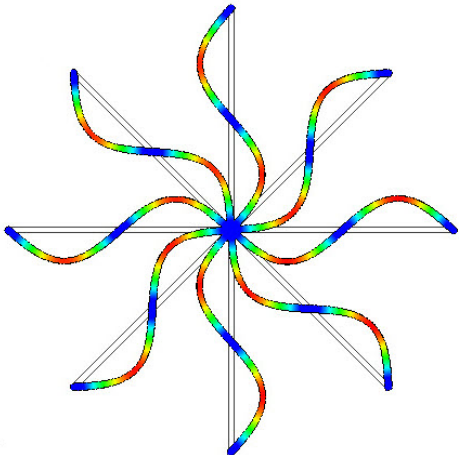

Results display in Algor 2011

1st mode shape

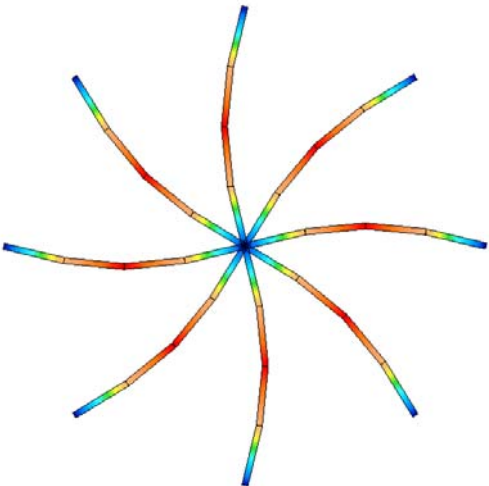

9th mode shape

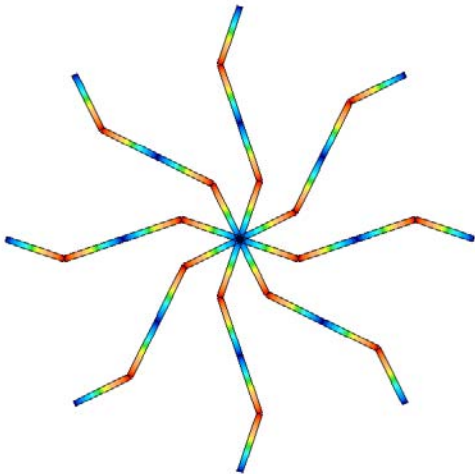

Comparison of Autodesk Simulation tools to NAFEMS Benchmarks

10. Vibration of a simply supported square plate

Case description

A square plate with thickness t is simply supported at four edges of the bottom surface. Determine the fourth to eighth natural frequencies of this plate.

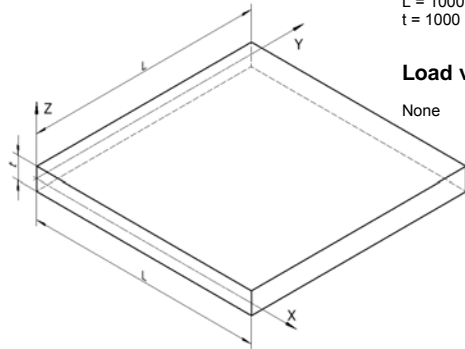

Material data

Steel	
Young's Modulus	2.0e+005 MPa
Poisson's Ratio	0.3
Mass Density	8e-006 kg/mm ³

Dimensions

$L = 10000$ mm
 $t = 1000$ mm

Load value

None

Mesh Settings

	Element type	Mesh size
Inventor 2011	All Tetrahedra	Default
Algor 2011	All Tetrahedra with midsides nodes	Default

Results Comparison

4 th to 8 th natural frequencies		F4	F5	F6	F7	F8
Comparison results*		45.897 HZ	109.44 HZ	109.44 HZ	167.89 HZ	193.59 HZ
Inventor 2011	Value	44.14 HZ	106.48 HZ	107.57 HZ	160.14 HZ	194.06 HZ
	Percentage Difference	3.83%	2.70%	1.71%	4.62%	0.24%
Algor 2011	Value	44.544 HZ	107.48 HZ	107.85 HZ	164.43 HZ	192.88 HZ
	Percentage Difference	2.95%	1.79%	1.45%	2.06%	0.37%

* Reference: NAFEMS Benchmark Test FV52

Results display in Inventor 2011

4th mode shape

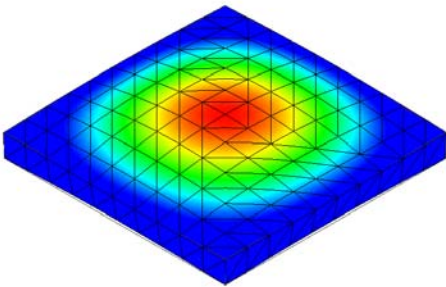

5th mode shape

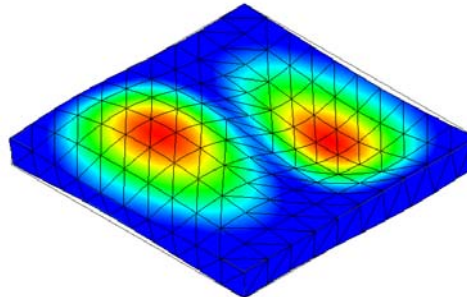

6th mode shape

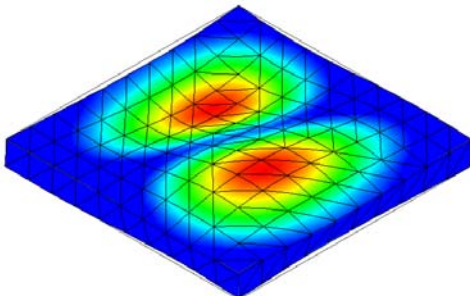

7th mode shape

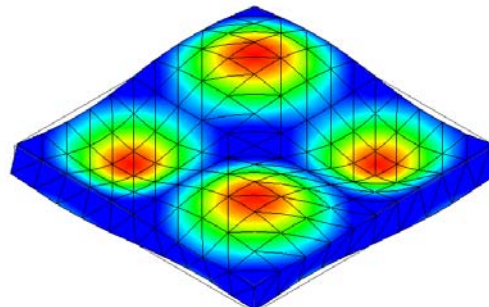

Comparison of Autodesk Simulation tools to NAFEMS Benchmarks

8th mode shape

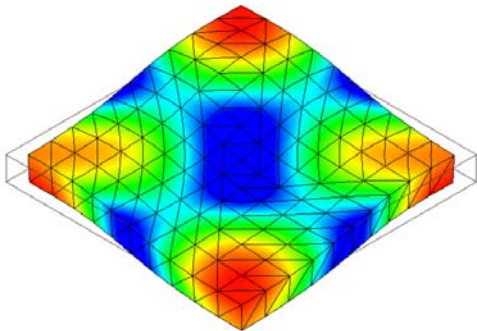

Results display in Algor 2011

4th mode shape

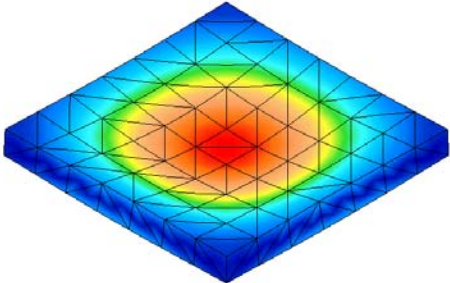

5th mode shape

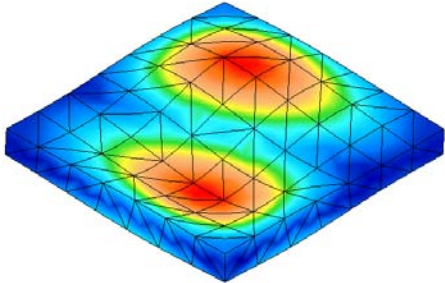

6th mode shape

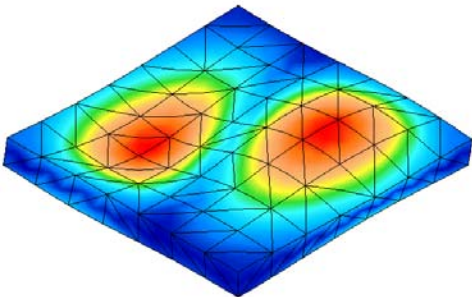

7th mode shape

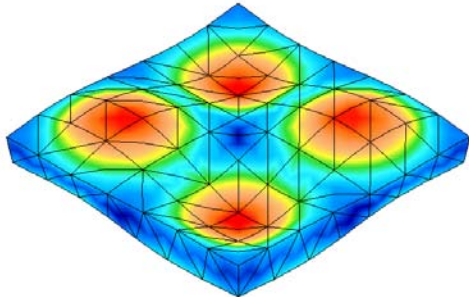

8th mode shape

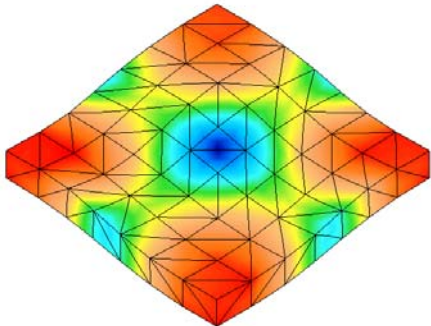

Autodesk and Autodesk Inventor are registered trademarks or trademarks of Autodesk, Inc., and/or its subsidiaries and/or affiliates in the USA and/or other countries. All other brand names, product names, or trademarks belong to their respective holders. Autodesk reserves the right to alter product offerings and specifications at any time without notice, and is not responsible for typographical or graphical errors that may appear in this document.

© 2011 Autodesk, Inc. All rights reserved.

Autodesk®