

The power of BIM
for structural engineering.

**Autodesk®
Revit®**

Structure

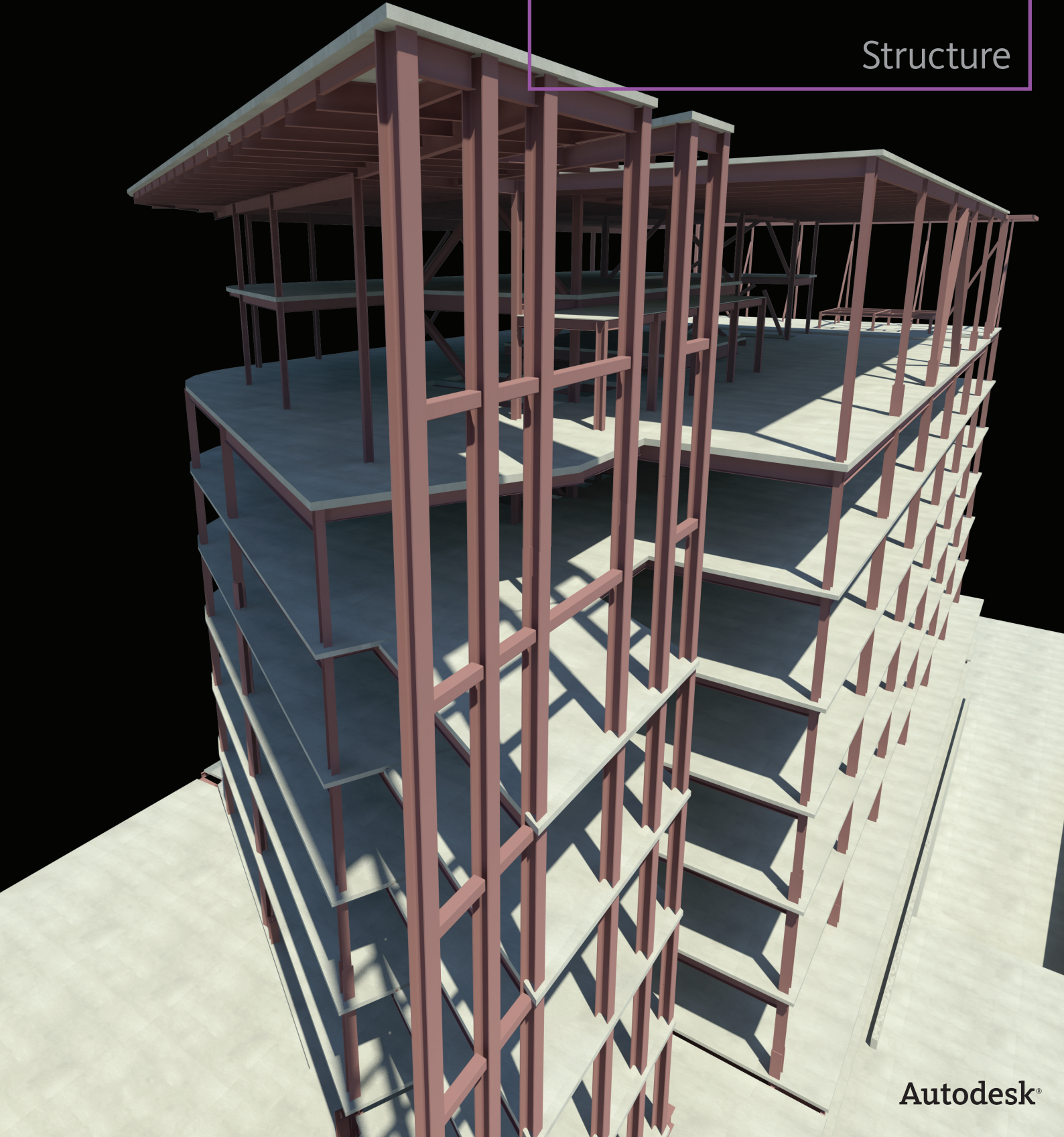

Improve Efficiency, Accuracy, and Coordination

Concurrent modeling for structural design, analysis, and coordinated documentation

Building information modeling significantly improves the quality and accuracy of the information that we push downstream. Our construction documents are created directly from the Autodesk Revit Structure model. If the model is correct, then the drawings are automatically correct. As a result, we are able to spend a lot less time producing documentation and more time up front modeling the structure.

—Jim Jacobi
Principal
Walter P. Moore

Autodesk® Revit® Structure software improves the way structural engineers and drafters work. Revit Structure helps minimize repetitive modeling and drawing tasks as well as errors due to manual coordination between structural engineers, architects, and drafters. The software helps reduce time spent producing final construction drawings and helps increase the accuracy of documentation, improving overall project deliverables for clients.

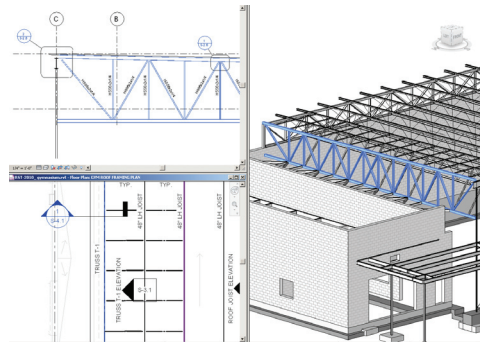

Smoother Coordination

Because Autodesk Revit Structure uses building information modeling (BIM), every view, drawing sheet, and schedule represents the same underlying database. As project team members work on the same project, making inevitable and necessary changes to the building structure, parametric change technology in Autodesk Revit Structure automatically coordinates changes across all other representations of the project—model views, drawing sheets, schedules, sections, plans, and details. The design and documentation stay coordinated, consistent, and complete.

Bidirectional Associativity

The building model and all of its views are part of the same information system. This means changes to any part of the structure need to be made only once, maintaining consistency throughout the documentation set. For example, if the sheet scale changes, the software automatically resizes annotations and graphics. If a structural member changes, any views that include the element are coordinated and updated automatically, including name tags and other labels referring to the element properties.

Collaboration with Architects

Engineers working with architects using Autodesk® Revit® Architecture software can experience the advantages of BIM and share the same underlying building database. Creation of the structural model is faster with integrated Autodesk Revit platform tools. With interference checking between structural and architectural objects, engineers can more quickly detect coordination problems before sending drawings to the construction site.

Collaboration with Mechanical, Electrical, and Plumbing Engineers

Structural engineers working with mechanical, electrical, or plumbing engineers using AutoCAD® MEP software can improve design coordination. Autodesk Revit Structure users can export their structural model into AutoCAD MEP, where the MEP engineer can perform clash detection between pipes and structural elements. Autodesk Revit Structure can also import 3D duct and pipe objects from AutoCAD MEP into the structural model via ACIS® solids to help detect interferences visually. In addition, structural engineers who are working with MEP engineers using Autodesk® Revit® MEP software can take better advantage of building information modeling.

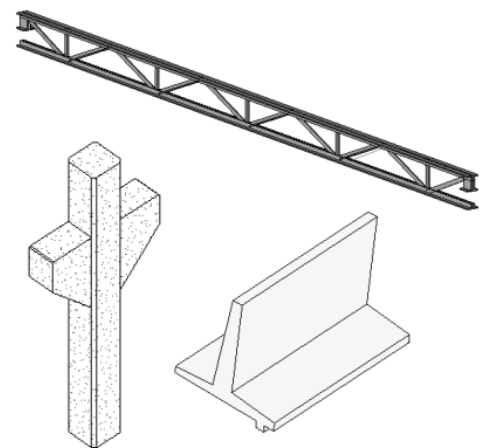

Enhance Structural Modeling and Analysis Capabilities

Help save time by creating physical and analytical structural models in a single application.

Whether engineers are designing steel, cast-in-place concrete, precast concrete, masonry, or wood structures, standard modeling objects in Autodesk Revit Structure software include walls, beam systems, columns, slabs, and foundations. Additional structural objects can be created as parametric components.

Parametric Components

Using Autodesk Revit Structure, engineers can create many types of structural components, such as joist systems, beams, open web joists, trusses, and intelligent wall families. No programming language is required to use parametric components, also known as *families*. The family editor contains all the data to graphically represent an element in 2D and 3D at various levels of detail.

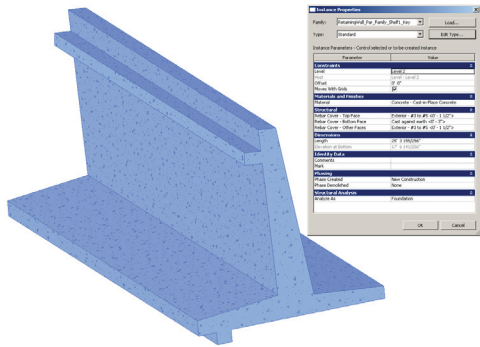

Multuser Collaboration

Autodesk Revit Structure enables multiple team members on the same network to work together on a model, while their work stays fully coordinated. A wide range of collaboration modes provides more flexibility to better meet the project team's workflow—from on-the-fly, simultaneous access to the shared model to formal division of the project into discrete shared units or individually managed linked models.

Design Options

With Autodesk Revit Structure, engineers can stay focused on structural engineering. The software enables users to explore design changes, develop and study several design alternatives to make key design decisions, and more easily present multiple schematic designs to clients. Each option can be substituted into the model for visualization and quantity takeoff to help team members and clients make more informed decisions.

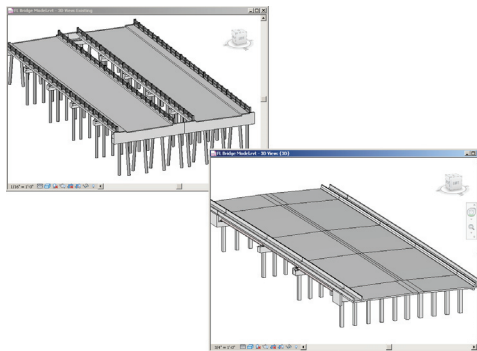

Leading Analysis and Design Integration

Analytical models created with Autodesk Revit Structure contain information such as loads, load combinations, member sizes, and release conditions. The analytical model can be the entire building model, one wing of the building, or even a single structural frame. Engineers use selection filters with structural boundary conditions to send substructures (such as a frame, floor, or wing of the building) to their analysis software without the need to send the entire model.

The creation of the analytical model uses engineering rules to produce a consistent analytical representation of the physical structure. Engineers can override initial analytical settings and edit the analytical model before linking to structural analysis packages.

Autodesk Revit Structure can inspire structural engineers to greater engineering insight: user-defined rules help the analytical models adjust their location to the analytical projection planes of attached or adjacent structural elements. Engineers can automatically check analytical inconsistencies such as missing supports, global instabilities, or framing anomalies before sending the model to structural analysis.

The analysis programs then return the design information and dynamically update the physical model and documentation, minimizing many redundant, repetitive tasks such as modeling frames and shells in a variety of different applications.

Autodesk Revit Structure integrates with Autodesk® Robot™ Structural Analysis Professional software as well as other widely used analysis and design applications. To find out which software partners have linked their applications to Autodesk Revit Structure through the Autodesk® Revit® platform API (application programming interface), visit <http://www.autodesk.com/revitstructure>.

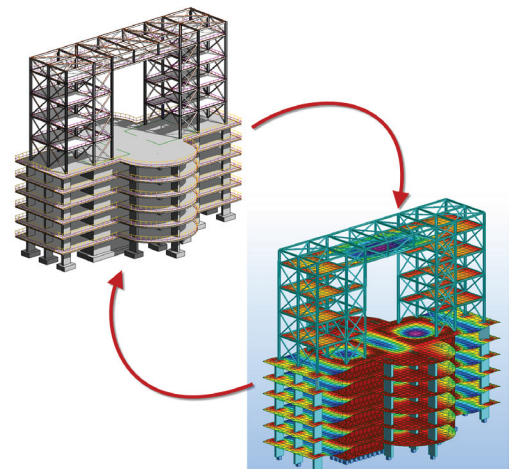

Deliver Comprehensive Construction Documents

Use a comprehensive set of dedicated tools to deliver structural drawings and help reduce errors due to manual coordination of design changes.

Material-specific tools help construction documents conform to industry and office standards.

For steel, features such as beam coping and automatic symbolic cutbacks as well as an extensive library of detail components, are available.

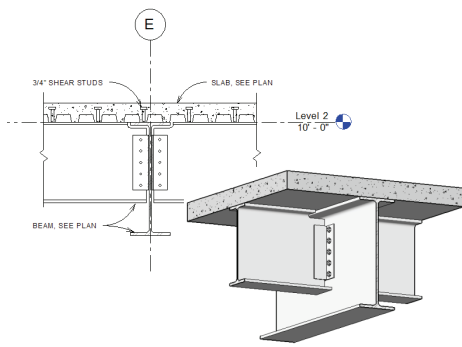

For concrete structures, display options provide control over the visibility of the concrete elements. Reinforcement bars are also available for concrete elements, including columns, beams, walls, and foundations.

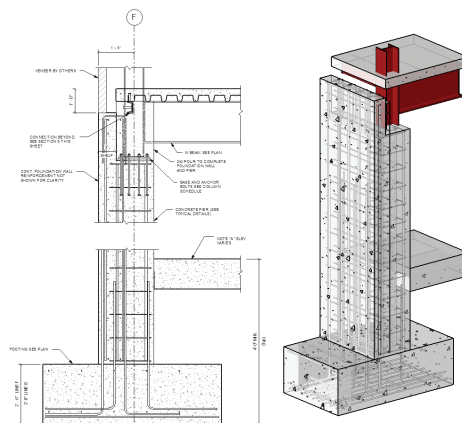

Automatic Sections and Elevations

Creating sections and elevations in Autodesk Revit Structure is more simple compared to traditional methods. Because views are just a different representation of the entire building model, users get cuts faster throughout a structure. Use them at any time to work in the most appropriate view. When the construction documents are ready to print, section tags and elevation symbols of the views that are not placed onto any drawing sheet are automatically hidden.

Automatic Drawing Sheet References

This functionality helps safeguard that no section, elevation, or callout references the wrong drawing or sheet and that all data and graphics, details, schedules, drawings, and sheets in the drawing set are current and coordinated.

Details

Autodesk Revit Structure allows callouts for typical details and for specific ones. Entire sheets of typical details can be created from scratch in Autodesk Revit Structure using its traditional 2D drafting tools.

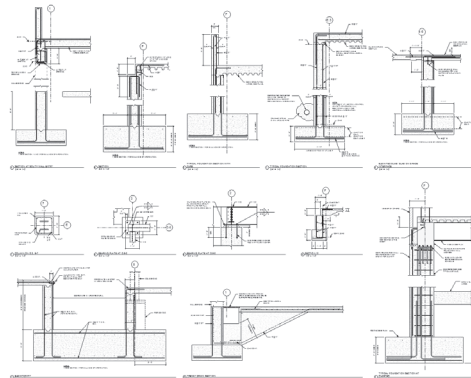

Designers can also import DWG details from AutoCAD® software and link them into Autodesk Revit Structure, using the project browser to manage them.

Specific details come directly from the views of the model. These model-based details are completed with 2D parametric components (metal deck, concrete masonry unit, anchor bolts in footings, fasteners, welded symbols, steel connection plates, concrete rebar, and more) and annotations such as text and dimensions.

When the geometry gets complicated, Autodesk Revit Structure offers 3D model-based details such as 3D representation of building expansion joints, steel connections, rebar in concrete elements, and more.

Schedules

Help save time by creating schedules on demand, and update the model and views automatically simply by making a change in a schedule. Schedule features include sorting, filtering, grouping, and counting as well as user-defined formulas.

| Structural Framing Schedule | | | | |
|-----------------------------|---------------|-------------|-----------------|-------|
| Type | Length | Camber Size | Number of studs | Count |
| 07 Penthouse T/Steel | | | | |
| W8X10 | 8' - 0" | | 8 | 5 |
| W1 2X14 | 14' - 8 1/4" | | 14 | 1 |
| W1 2X19 | 17' - 4" | | 18 | 1 |
| W1 2X19 | 29' - 9 1/4" | c=3/4" | 30 | 1 |
| W1 2X19 | 29' - 11 1/8" | c=3/4" | 30 | 1 |
| W1 2X19 | 30' - 10 5/8" | c=3/4" | 30 | 1 |
| W1 2X19 | 31' - 1 3/4" | c=3/4" | 32 | 1 |
| W1 2X19 | 31' - 2 1/4" | c=1" | 32 | 1 |
| W1 2X19 | 32' - 0" | | 32 | 1 |
| W1 4X22 | 8' - 0" | | 8 | 8 |
| W1 4X22 | 10' - 6" | | 10 | 1 |
| W1 4X22 | 12' - 0" | | 12 | 1 |
| W1 4X22 | 17' - 6 7/8" | | 18 | 1 |
| W1 4X22 | 19' - 0 3/8" | | 20 | 1 |
| W1 4X22 | 32' - 0" | | 32 | 6 |
| W1 6X26 | 14' - 8 1/4" | | 14 | 1 |
| W1 6X26 | 15' - 3 3/8" | | 16 | 1 |
| W1 6X26 | 32' - 0" | c=1" | 32 | 1 |
| W1 6X26 | 36' - 7 3/8" | c=1" | 36 | 1 |
| W1 6X26 | 40' - 0" | c=1 3/4" | 40 | 1 |
| W1 6X36 | 44' - 3 1/8" | c=1 1/2" | 44 | 1 |
| W1 6X45 | 48' - 0" | c=1 3/4" | 48 | 36 |
| W1 6X50 | 48' - 3 3/8" | c=1 3/4" | 48 | 2 |
| W1 6X50 | 49' - 0 3/4" | c=2" | 50 | 2 |
| W1 6X57 | 50' - 4 1/2" | c=2" | 50 | 2 |
| W1 6X67 | 52' - 3" | c=2" | 52 | 2 |
| W1 8X35 | 29' - 4 7/8" | | 30 | 1 |
| W24X76 | 28' - 0" | c=1" | 28 | 4 |
| W24X76 | 36' - 0" | | 36 | 14 |
| 06 Roof T/Steel | | | | |
| CBX11.5 | 4' - 10 1/2" | | 4 | 1 |
| HSS8X8X.250 | 39' - 1 3/4" | | | 4 |
| HSS8X8X.3125 | 18' - 4 5/8" | | | 1 |
| HSS8X8X.3125 | 18' - 8 1/2" | | | 1 |
| HSS8X8X.3125 | 18' - 9 7/8" | | | 4 |
| HSS8X8X.3125 | 19' - 2 3/4" | | | 1 |
| HSS8X8X.3125 | 19' - 4" | | | 1 |
| W8X10 | 4' - 10 1/2" | | 4 | 2 |
| W8X10 | 5' - 3 3/4" | | 6 | 2 |
| W8X10 | 6' - 11 1/4" | | 6 | 2 |

Engineers and project managers can use customized schedules to check the overall structural design. For example, they can schedule and review structural loads before integrating the model with analysis software. If the load value needs to be changed, it can be modified in the schedule and automatically coordinated throughout the model.

Building Information Modeling for Structural Engineering

Make better decisions, earlier in the design process by more accurately visualizing and analyzing structures, before they are built.

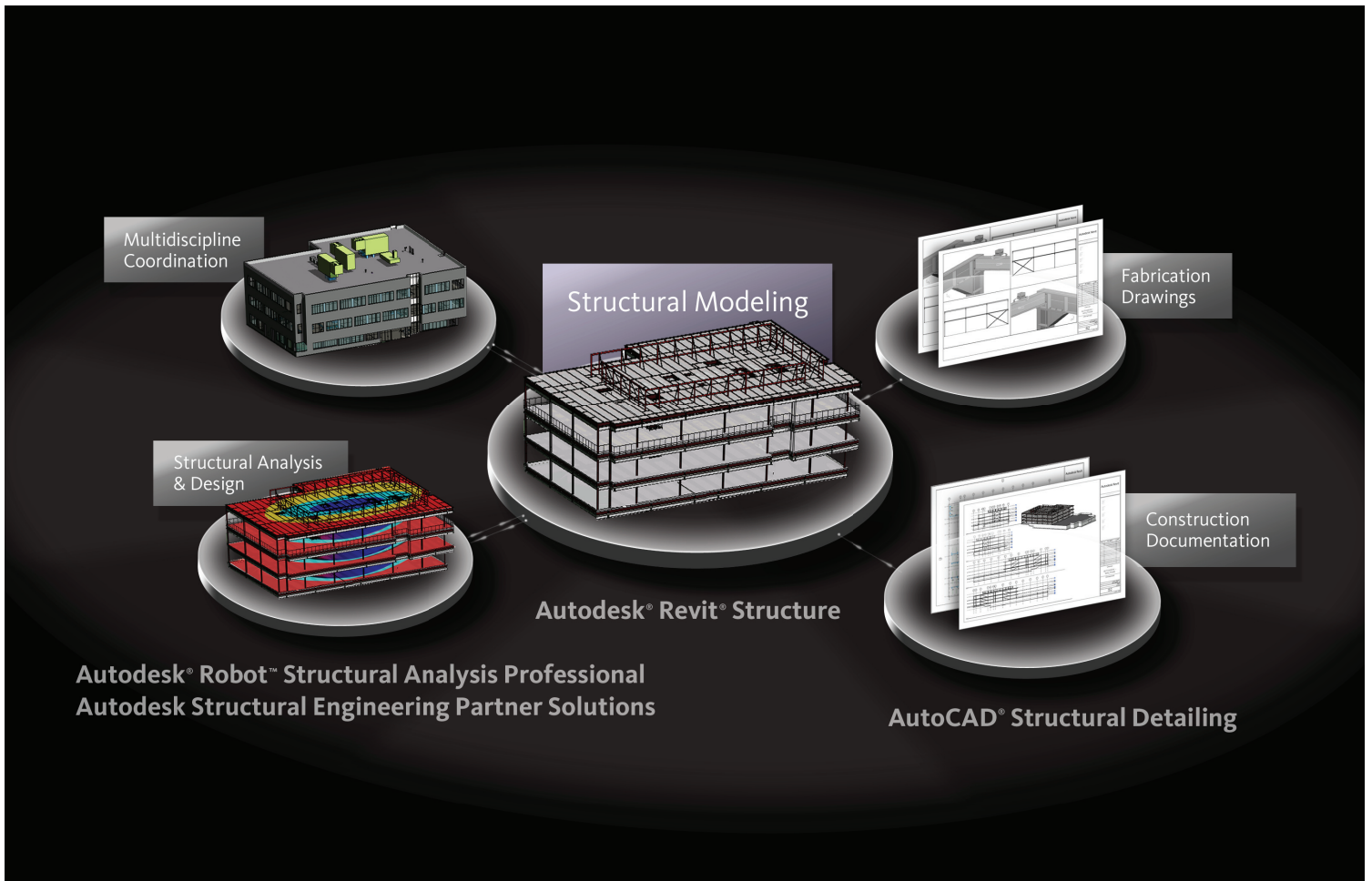

Building information modeling (BIM) is an integrated process built on coordinated, reliable information about a project from design through construction and into operations. By adopting BIM, architects, engineers, contractors, and owners can more easily create coordinated, digital design information and documentation; use that information to visualize, simulate, and analyze performance, appearance, and cost; and reliably deliver the project faster, more economically, and with reduced environmental impact.

BIM for structural engineers follows this same methodology for the entire structural engineering process, focusing on a digital model that can be used for coordination with architects; mechanical, electrical, and plumbing engineers; and civil engineers that is integrated with analysis, design, and construction documentation, and extending that digital model from design through fabrication and construction.

Autodesk Revit Structure

Autodesk® Revit® Structure software is the building information modeling (BIM) solution for structural engineers, providing purpose-built tools for structural design, analysis and documentation. Make better decisions, earlier in the design process by more accurately visualizing and analyzing structures, before they are built.

We had been watching building information modeling for several years but were unable to find a structural design product that did what we needed. When we saw the demo of Autodesk Revit Structure, we knew that there was finally a solution.

—David Pluke
Principal and VP of Technology
Ericksen Roed & Associates, Inc.

Learn More or Purchase

Access specialists worldwide who can provide product expertise, a deep understanding of your industry, and value that extends beyond your software. To license Autodesk Revit Structure software, contact an Autodesk Premier www.autodesk.com/reseller.

Autodesk Learning and Education

From instructor-led or self-paced classes to online training or education resources, Autodesk offers learning solutions to fit your needs. Get expert guidance at an Autodesk Authorized Training Center (ATC[®]) site, access learning tools online or at your local bookstore, and validate your experience with Autodesk certifications. Learn more at www.autodesk.com/learning.

Autodesk Services and Support

Help accelerate return on investment and optimize productivity with companion products, consulting services, and support from Autodesk and Autodesk authorized partners. Designed to get you up to speed and keep you ahead of the competition, these tools help you make the most of your software—no matter what industry you are in. Learn more at www.autodesk.com/servicesandsupport.

Autodesk Subscription

Autodesk[®] Subscription gives you immediate access to software upgrades and exclusive access to service and support benefits designed to help you get the most out of your Autodesk software. Learn more at www.autodesk.com/subscription.